

POLICY NO. 02-10-2015(a)
VILLAGE OF PRAIRIE DU SAC
MAILBOX INSTALLATION & REPLACEMENT POLICY

I. INTRODUCTION

The Public Works Department has many operations that require various types of vehicles and equipment to work along the street gutter and curb line. These operations include snow removal and plowing, mechanical sweeping, brush and leaf pickup. Performing these operations requires the Public Works Department to plow or clean as close to the curb as possible. The Public Works Department takes great care not to damage any property within the Village right-of-way; however, mailboxes do occasionally get damaged.

In the majority of cases, the Village has repaired or replaced all mailboxes that residents claimed were damaged by its various operating vehicles and equipment. Due to the time and cost associated with these repairs and replacements, the Village has established a policy for mailbox repairs and new mailbox installation.

II. POLICY

The Public Works Department will repair or replace any damaged standard mailbox and/or support post when the following two (2) criteria are met:

1. It is determined that the Village operator damaged the mailbox while operating within the street gutter and curb line; and
2. The mailbox had been properly installed (e.g., meeting United States Postal Service (USPS) installation guidelines discussed below) and maintained prior to the damage occurring.

If both criteria noted above are met, the Village of Prairie du Sac will repair or replace a mailbox with the standard mailbox and/or support post the Village offers. If the mailbox owner does not want the standard mailbox and/or support post, the owner may repair or replace the mailbox/post at his/her own cost. The Village of Prairie du Sac will then reimburse the mailbox owner up to a maximum of \$50.00 (copies of receipts are needed). If your mailbox claim exceeds the \$50.00 maximum, you must file a proper claim with the Village of Prairie du Sac Clerk's Office pursuant to Section 893.80 of the Wisconsin Statutes.

Any mailbox damaged by the weight of the plow windrow (snow exiting the end of the plow) will not be covered under this policy.

Guidelines established per United States Postal Service (USPS) regulations regarding mailbox installation:

- Mailboxes shall be installed 41 to 45 inches above the street surface to the bottom of the mailbox (see diagram).
- Mailboxes shall be set back 6 to 8 inches from the front face of the curb or road edge to the mailbox door (see diagram).

Mailbox Location (POM 632)

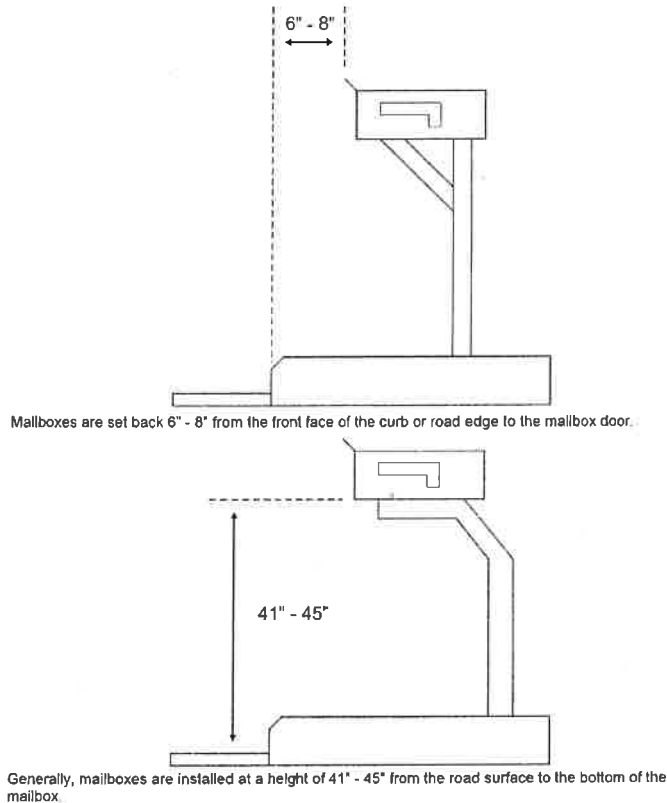

Mailbox owners can contact the USPS at (800) 275-8777 with any questions regarding USPS mailbox installation guidelines.

DO NOT use concrete to secure your mailbox post. Instead, use 1/4" screenings (1/4" gravel with fines) or compacted sand. The Village will not remove concrete and will only trim broken post to the top surface of the concrete. Placement of the new post will be to either side of the existing concrete, unless the mailbox owner specifies a new location or removes any existing concrete.

This policy shall be in full force and effect upon its passage by the Village Board of Trustees.

Approved and adopted this 10th of February, 2015.

Village President

Village Administrator